

TNC8305WP-0085

TNC Jack Solder For Bulkhead

50Ω

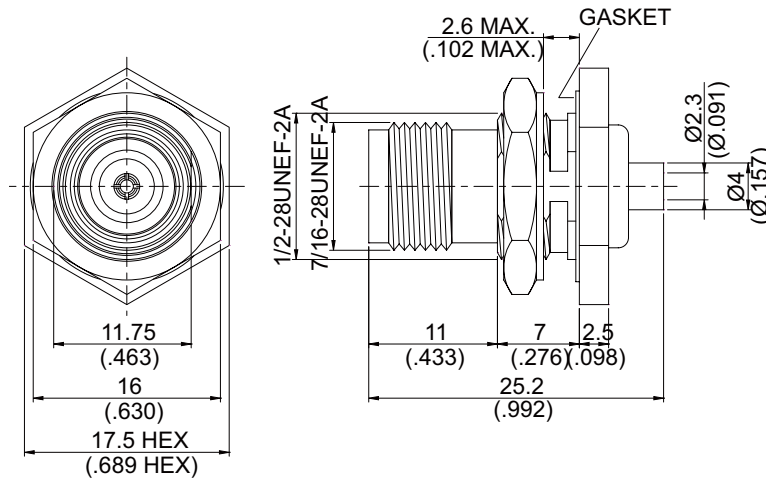

MOUNTING HOLE

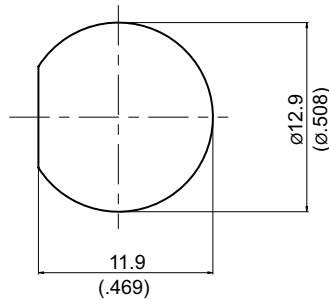

NOTE: IP67 compliant (waterproof) when mated.

Parts	Material	Plating (Micro-inch)
Gasket	Silicon	
Ferrule	Brass	Tin-Zinc-Copper-Alloy 100 Over Copper 50
Contact Pin	Phosphor Bronze	Gold 4 Over Nickel Phosphorus Alloy 80 Over Copper 20
Hex Nut	Brass	Tin-Zinc-Copper-Alloy 100 Over Copper 50
Washer	Brass	Tin-Zinc-Copper-Alloy 100 Over Copper 50
Barrel	Brass	Tin-Zinc-Copper-Alloy 100 Over Copper 50
Insulator	Teflon	
Body	Brass	Tin-Zinc-Copper-Alloy 100 Over Copper 50

Weight:

Suitable Cables: Semi-rigid.085

This part number complies with RoHS.

Notice: JYEBAO reserves the right to make modifications deemed appropriate.

CABLE ASSEMBLY INSTRUCTION

TNC8305WP-0085

JYE BAO CO., LTD.

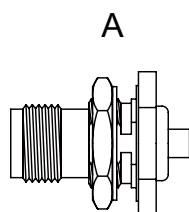

**BODY+GASKET
+WASHER+HEX NUT**

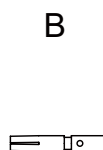

CONTACT PIN

DIAGRAM

ASSEMBLY INSTRUCTION



Step 1: STRIP AS SHOWN .

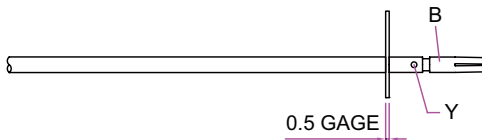

Step 2: PUT 0.5 MM GAGE IN PLACE, INSERT CABLE'S CENTER CONDUCTOR INTO CENTER PIN " B " AND SOLDER IN " Y " .

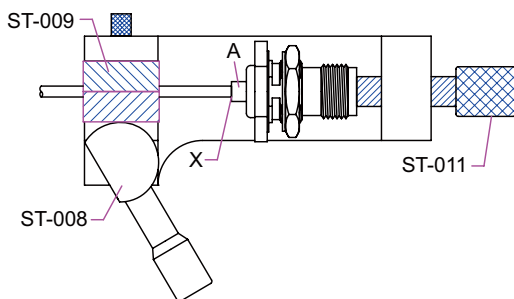

Step 3: INSERT PREPARED CABLE INTO CONNECTOR BODY " A " AND USE SOLDERING FIXTURE " ST-008 " , INSERT TOOL " ST-009 " AND LOCATOR TOOL " ST-011 " TO FIX THE CONNECTOR. SOLDER IN " X " .

This part number complies with RoHS.

Notice: JYEBAO reserves the right to make modifications deemed appropriate.